

Product Overview

SFP-Transceiver for extended temperature range



Description

The majority of all active network devices are now equipped with modular optical interfaces in the form of SFP ports. For the user this permits the highest possible flexibility in terms of network configuration.

MICROSENS provides a special range of SFP transceivers with extended temperature range especially for the insertion into network devices intended for operation in rough environments. The temperature range for operation is from -40 to +85 °C.

These SFP transceivers generally have an integrated digital diagnostics function and, depending on the version, are designed for Fast Ethernet (100Base-FX) or Gigabit Ethernet (1000Base-SX/LX). Multimode and single mode versions with different optical budget are available.

Properties

- Extended temperature range -40..+85 °C
- Installation during operation (hot swap)
- Versions for Fast Ethernet and Gigabit Ethernet
- Simplex WDM option (simplex fiber)
- Digital diagnostic functions

Dimensions

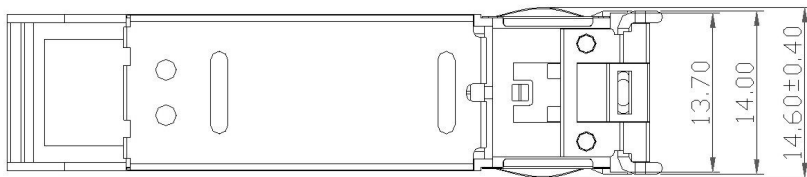
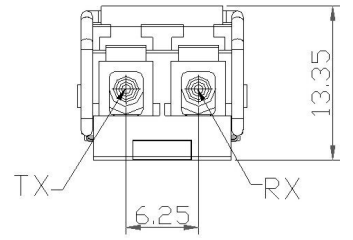
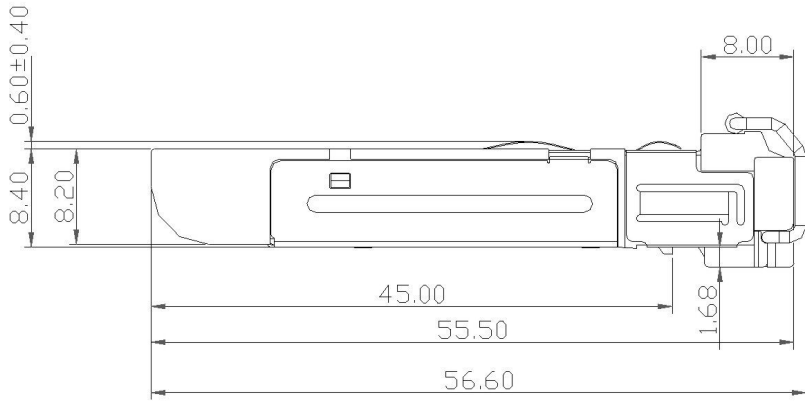
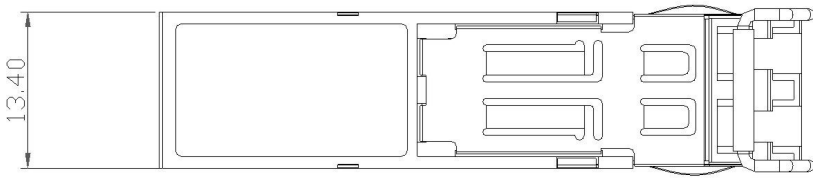

Specifications

General

Type	Small form-factor pluggable (SFP) Transceiver with extended temp. range
Performance	Fast Ethernet or Gigabit-Ethernet (see article-no.)
Management	Digital diagnostic functions

Power Supply (DC)

Input Voltage	3,3 V
----------------------	-------

Mechanical

Dimensions	56,6 mm x 14 mm x 8,4 mm (L x H xW)
Weight	17 g
Mounting	For SFP slots

Optical Parameter

Number of Ports	1
Fiber Cable Type	Multimode: 50 or 62.5/125 µm fiber Single Mode: 9/125 µm fiber
Connector	1x LC duplex

Environment

Operating Temperature	-40..+85°C
Storage Temperature	-40..+85°C

Standards Compliance

Other	CDRH IEC 825-1 class 1 eye safety MultiSource Agreement (MSA)
--------------	---

Order Information

Description	Article Number
-------------	----------------

Fast Ethernet

SFP Fast Ethernet Transceiver 100Base-FX, Multimode 1310nm, digital Diagnostics, -40..85°C	MS100190DX
--	-------------------

SFP Fast Ethernet Transceiver 100Base-FX, Monomode 1310nm, digital Diagnostics, -40..85°C	MS100191DX
---	-------------------

Gigabit Ethernet

SFP Gigabit Ethernet Transceiver 1000Base-SX, Multimode 850nm, digital Diagnostics, exten. temp.-range: -40..85°C	MS100200DX
---	-------------------

SFP Gigabit Ethernet Transceiver 1000Base-LX, Single Mode 1310nm, digital Diagnostics, -40..85°C	MS100210DX
--	-------------------

SFP Gigabit Ethernet Transceiver 1000Base-LX, Single Mode 1310nm, min. 25km, digital Diagnostics, -40..85°C	MS100211DX
---	-------------------

WDM (Simplex)

SFP Pluggable Transceiver Fast Ethernet BiDi WDM Monomode LC simplex Tx: 1310nm Rx: 1550nm, min 20km, -40..75°C	MS100191DXA
---	--------------------

SFP Pluggable Transceiver Fast Ethernet BiDi WDM Monomode LC simplex Tx:1550nm Rx: 1310nm, min 20km, -40..75°C	MS100191DXB
--	--------------------

SFP Gigabit Ethernet Transceiver 1000Base-BX, Single Mode 11dB/10km, Tx: 1310nm, Rx: 1550nm, digital Diagnostics, -40..85°C	MS100221DXA
---	--------------------

SFP Gigabit Ethernet Transceiver 1000Base-BX, Single Mode 11dB/10km, Tx: 1550nm, Rx: 1310nm	MS100221DXB
---	--------------------

SFP Gigabit Ethernet Transceiver 1000Base-BX, Single mode 11dB/10km, Tx: 1310nm, Rx: 1490nm, -40..+85°C	MS100222DXA
---	--------------------

SFP Gigabit Ethernet Transceiver 1000Base-BX, Single mode 11dB/10km, Tx: 1490nm, Rx: 1310nm, -40..+85°C	MS100222DXB
---	--------------------

SFP Gigabit Ethernet Transceiver 1000Base-BX, Single mode 13dB/20km, Tx: 1310nm, Rx: 1490nm, -40..+85°C	MS100223DXA
---	--------------------

SFP Gigabit Ethernet Transceiver 1000Base-BX, Single Mode 13dB/20km, Tx: 1490nm, Rx: 1310nm digital Diagnostics, -40..85°C	MS100223DXB
--	--------------------

SFP Gigabit Ethernet Transceiver 1000Base-BX, Single Mode 19dB/40km, Tx: 1310nm, Rx: 1550nm, digital Diagnostics, -40..85°C	MS100224DXA
---	--------------------

SFP Gigabit Ethernet Transceiver 1000Base-BX, LC-simplex Single Mode 19dB/40km, Tx: 1550nm, Rx: 1310nm, digital Diagnostics, -40..85°C	MS100224DXB
--	--------------------

SFP Gigabit Ethernet Transceiver 1000Base-BX, Single Mode 23dB/60km, Tx: 1310nm, Rx: 1550nm digital Diagnostics, -40..85°C	MS100225DXA
--	--------------------

SFP Gigabit Ethernet Transceiver 1000Base-BX, Single Mode 23dB/60km, Tx: 1310nm, Rx: 1550nm digital Diagnostics, -40..85°C	MS100225DXB
--	--------------------

This document in whole or in part may not be duplicated, reproduced, stored or retransmitted without prior written permission of MICROSENS GmbH & Co. KG. All information in this document is provided 'as is' and subject to change without notice. MICROSENS GmbH & Co. KG disclaims any liability for the correctness, completeness or quality of the information provided, fitness for a particular purpose or consecutive damage. MICROSENS is a trademark of MICROSENS GmbH & Co. KG. Any product names mentioned herein may be trademarks and/or registered trademarks of their

respective companies.

© 2015.05.13 MICROSENS GmbH & Co. KG - 59067 Hamm/Germany - Tel. +49 2381 9452-0 - www.microsens.com